

Features

- Frequency: 0.4GHz~0.6GHz
- Gain: 35dB
- Noise Figure: 0.6dB
- Supply Voltage: +4.5V@75mA
- Die Size: 1.3mm×1.25mm×0.1mm

Typical Applications

- Radar and ECM
- RF/ Microwave radio
- Military and Space
- Test and Measurement
- Fiber Optics

General Description

SAC3006 is a GaAs MMIC low noise amplifier die which operates between 0.4GHz~0.6GHz. The amplifier can provide 35dB gain, 17.5dBm OutputP_{1dB} and 0.6dB noise figure from a 75mA supply current.

The chip offers full passivation for increased reliability and moisture protection. This amplifier is the perfect alternative to higher cost hybrid amplifiers.

Functional Diagram

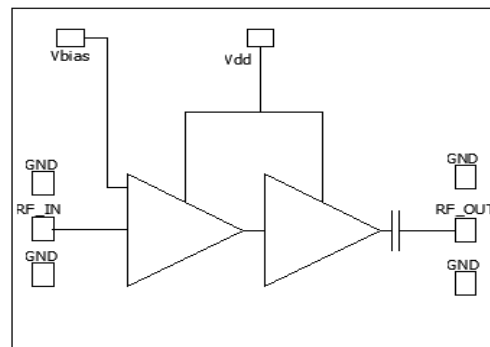

Electrical Performance (T_A=25°C, V_D=+4.5V, I_D=75mA, Z₀=50Ω)

Parameter	Min.	Typ.	Max.	Units
Frequency Range	0.4~0.6			GHz
Gain	—	35	—	dB
Gain Flatness	—	0.2	—	dB
Reverse Isolation	—	-52	—	dB
Input/Output VSWR	—	1.8	—	:1
Noise Figure	—	0.6	—	dB
Output Power for 1 dB Compression (OP _{1dB})	—	17.5	—	dBm
Output Third Order Intercept (OIP ₃)	—	28	—	dBm
Supply Current(I _D)	—	75	—	mA

Absolute Maximum Ratings

Maximum Input Power	+18dBm	Operating Temperature	-55°C~+85°C
Channel Temperature	+150°C	Storage Temperature	-65°C~+150°C

Typical Performance Curve

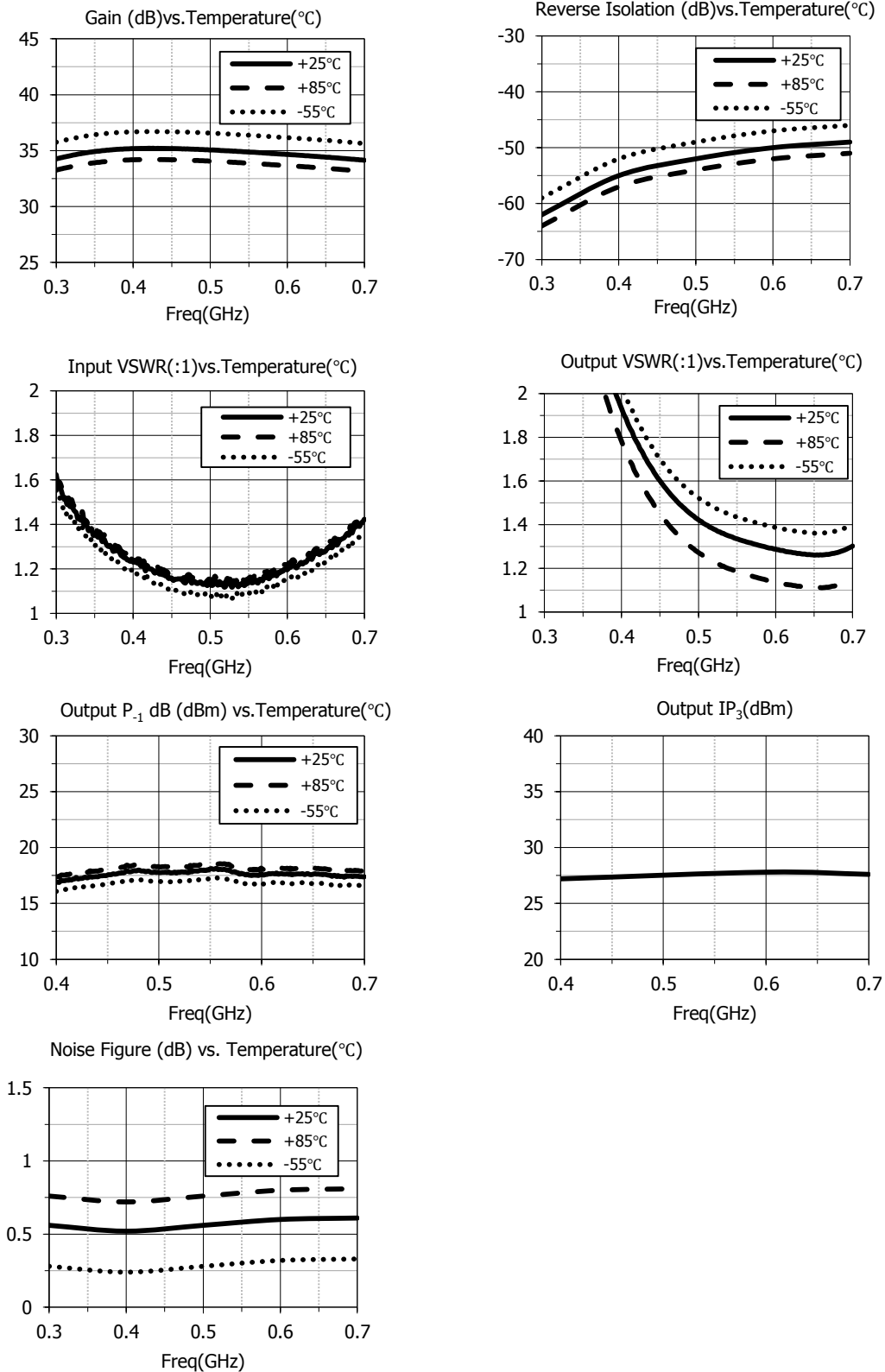

SAC3006

GaAs MMIC Low Noise Amplifier
0.4GHz~0.6GHz

Rev 2.0

Die Outline
(All dimensions in mm)

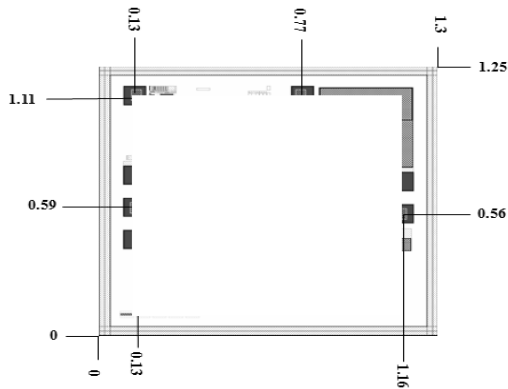

Assembly Diagram

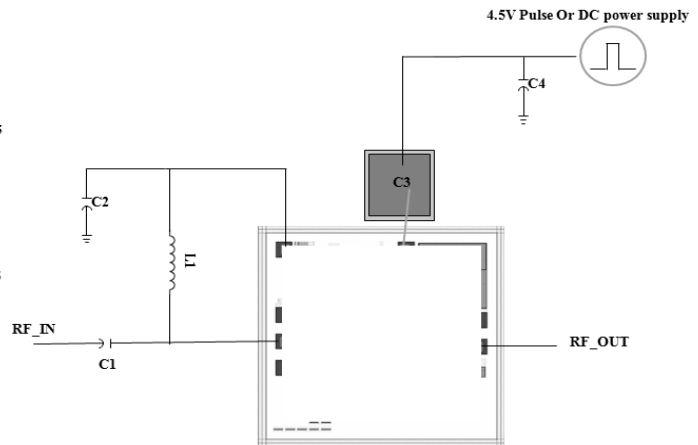

Components List

Reference Des.	Value	Part Number	Manuf.	Size
C1	47pF	GRM1555C1H470JZ01D	MURATA	0402
C2	100pF	GRM1555C1H101JA01D	MURATA	0402
C3	300pF	—	RADVISTA	Chip
C4	10nF	GRM155R71H103KA88D	MURATA	0402
L1	68nH	0402CS-68NXGE	COILCRAFT	0402

Attention:

GaAs MMIC devices are susceptible to damage from Electrostatic Discharge. Proper precautions should be observed during handling, assembly and test.