

Features

- Frequency: 1.2GHz~1.4GHz
- Gain: 21dB
- Noise Figure: 0.9dB
- Supply Voltage: +5V@100mA
- Package Size: 3×3×1.2mm

Typical Applications

- Radar and ECM
- RF/ Microwave radio
- Military and Space
- Test and Measurement
- Fiber Optics

General Description

SAC3022Q3 is a GaAs MMIC low noise amplifier die which operates between 1.2GHz~1.4GHz. The amplifier can provide 21dB gain, 22dBm Output P_{1dB} and 0.9dB noise figure from a 100mA supply current.

The chip offers full passivation for increased reliability and moisture protection. This amplifier is the perfect alternative to higher cost hybrid amplifiers.

Functional Diagram

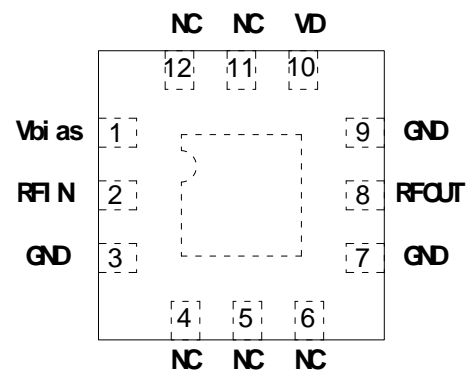

Electrical Performance (T_A=25°C, V_D=+5V, I_D=100mA, Z₀=50Ω)

Parameter	Min.	Typ.	Max.	Units
Frequency Range	1.2~1.4			GHz
Gain	19	21	23	dB
Gain Flatness	—	0.5	1.0	dB
Reverse Isolation	—	-28	-25	dB
Input/Output VSWR	—	1.5	—	:1
Noise Figure	—	0.9	1.0	dB
Output Power for 1 dB Compression (OP _{1dB})	20	22	—	dBm
Output Third Order Intercept (OIP ₃)	30	32.5	—	dBm
Supply Current(I _D)	—	100	—	mA

Absolute Maximum Ratings

Maximum Input Power	+18dBm	Operating Temperature	-55°C~+85°C
Channel temperature	+150°C	Storage Temperature	-65°C~+150°C

Typical Performance Curve

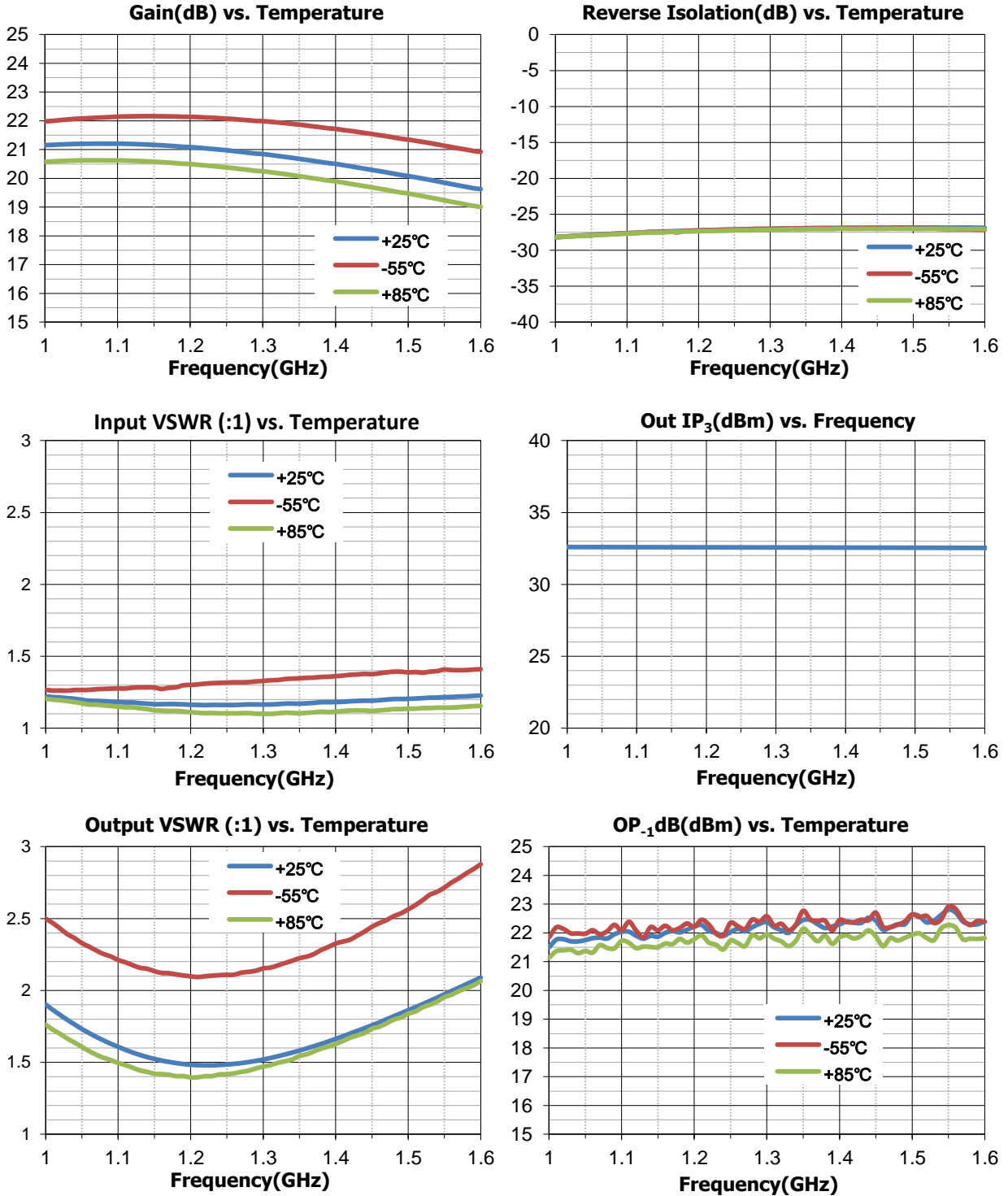

SAC3022Q3

GaAs MMIC Low Noise Amplifier
1.2GHz~1.4GHz

Rev 2.1

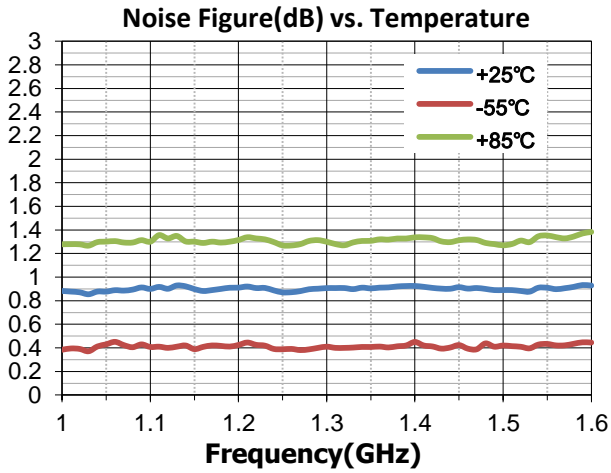

Outline Drawing
(All dimensions in mm)

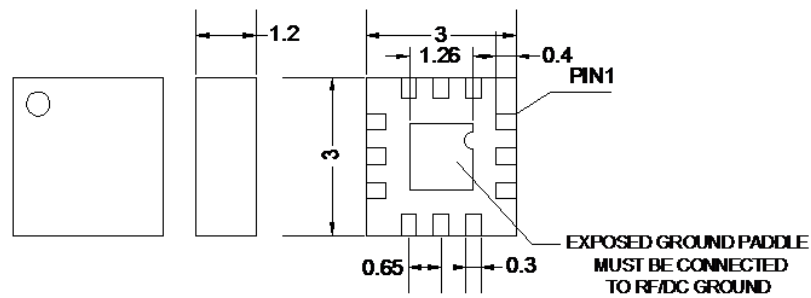

Application Circuit Configuration

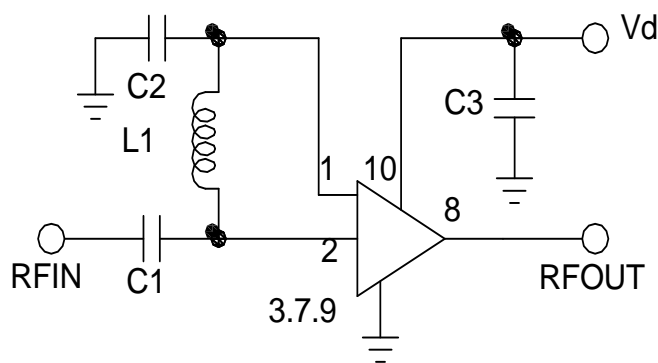

SuperApex, LLC

1580 S. Milwaukee Ave. Suite 405, Libertyville, IL 60048, USA
 Tel: 1-847-505-8319, 1-847-573-9866
 E-mail: sales@superapexco.com
 Website: www.superapexco.com

Components List

Reference Des.	Value	Part Number	Manuf.	Size
C1	22pF	GRM1555C1H220JA01D	MURATA	0402
C2	33pF	GRM1555C1H330JA01D	MURATA	0402
C3	10nF	GRM1857U1A103JA44	MURATA	0402
L1	27nH	0402CS-27NXGE	COILCRAFT	0402

Attention:

1. The moisture resistant grade of products is 2A, the storage environment $\leq 30^{\circ}$ C/60% RH, The surrounding workshop Life is 4 weeks.
2. After un-packing, It is necessary to bake the parts for 6 hours in 125+/-5 degree environment before soldering.