

# SAC1002Q3



GaAs MMIC Envelope Detector  
1~40GHz

Rev 1.2

## Features

- Frequency: 1~40GHz
- Dynamic Range: 30dB
- BCB Layer Protected
- Package Size: 3mm×3mm×1.1mm

## Typical Applications

- Radar and ECM
- RF/ Microwave Radio
- Test and Measurement
- Instrumentation

## General Description

SAC1002Q3 is an envelope detector that integrates a matched detection diode (Vdet). A reference diode is also available to be used in differential mode (Vref).

It is designed for wide range of applications where an accurate transmitted power control is required, typically commercial communication systems.

SAC1002Q3 is assembled in a 3mm×3mm QFN plastic package.

## Functional Diagram

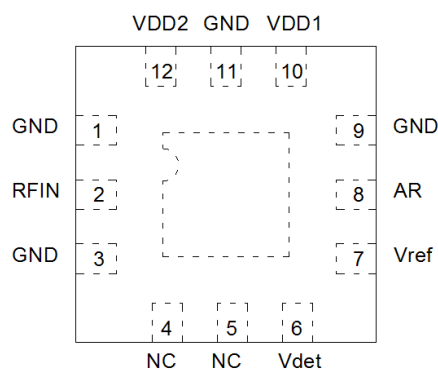

## Electrical Performance ( $T_A=+25^\circ\text{C}$ , $V_D=+5\text{V}$ , $Z_0=+50\Omega$ )

Parameter	Min.	Typ.	Max.	Units
Frequency	1~40			GHz
Flatness	—	2	—	dB
Dynamic Range	—	30	—	dB
Input Return Loss	—	-10	—	dB
Rise Time	—	50	—	ns
Fall Time	—	300	—	ns
$I_D$	—	2	—	mA

## Absolute Maximum Ratings

Maximum Input Power detection	+18dBm	Operating temperature range	-55°C~+85°C
$V_D$	+6V	Storage temperature range	-65°C~+150°C

## SuperApex, LLC

1580 S. Milwaukee Ave. Suite 405, Libertyville, IL 60048, USA  
Tel: 1-847-505-8319, 1-847-573-9866  
E-mail: sales@superapexco.com  
Website: www.superapexco.com

# SAC1002Q3



GaAs MMIC Envelope Detector  
1~40GHz

Rev 1.2

## Application 1 (1~40GHz detector)

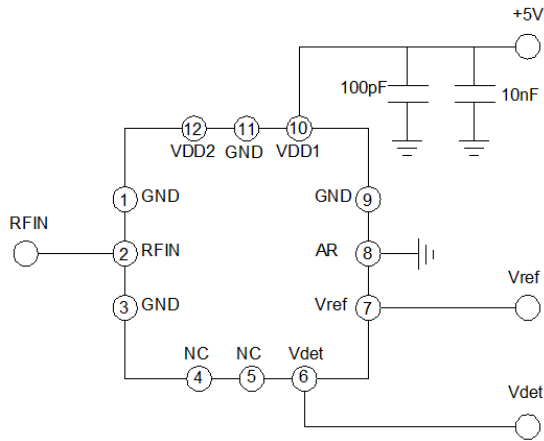

## Typical Performance Curve

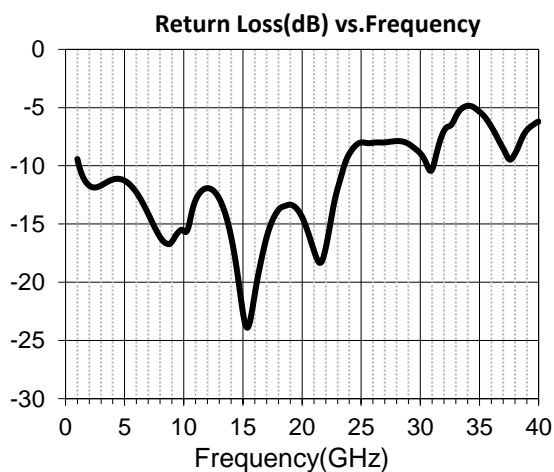
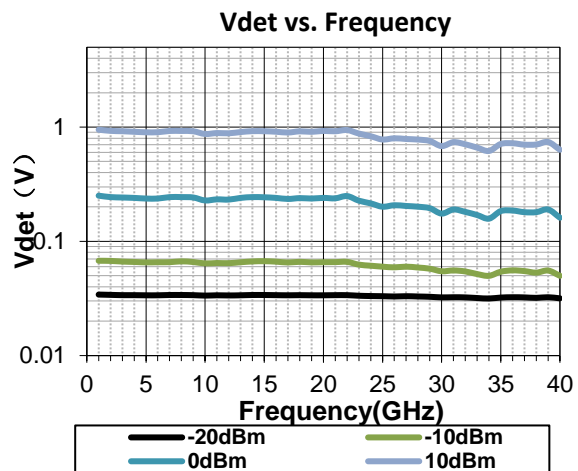
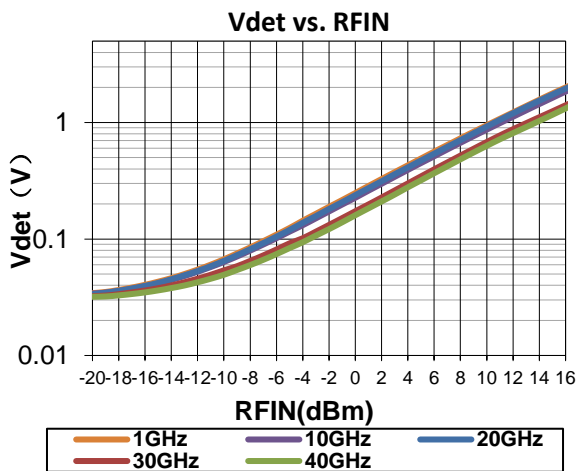

### SuperApex, LLC

1580 S. Milwaukee Ave. Suite 405, Libertyville, IL 60048, USA  
 Tel: 1-847-505-8319, 1-847-573-9866  
 E-mail: sales@superapexco.com  
 Website: www.superapexco.com

## Application 2 (1~40GHz BITE)

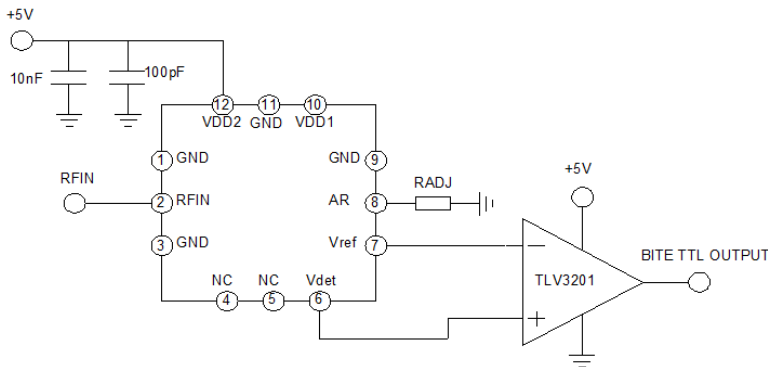

The circuit is used in built-in test equipment. Resistor R1 sets threshold power. When the input signal is higher than threshold power, the comparator generates output TTL high level. R1: 510Ω~5.1KΩ.

## Outline Drawing (All dimensions are in mm)

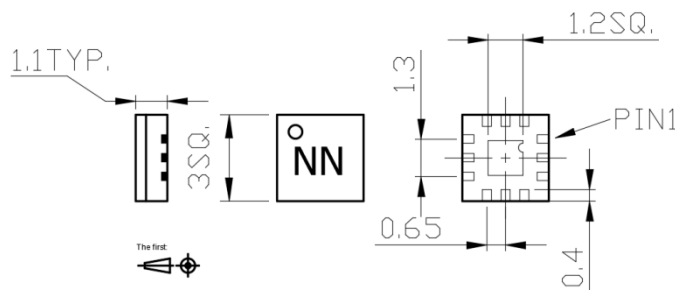

## ESD CAUTION



ESD (electrostatic discharge) sensitive device. Charged devices, the circuit boards, can discharge without detection. Damage may occur on devices subjected to high energy ESD. Therefore, proper ESD precautions should be taken to avoid performance degradation or loss of functionality.

### Attention:

1. The moisture resistant grade of products is 2A, the storage environment  $\leq 30^{\circ} \text{C}/60\% \text{RH}$ , The surrounding workshop Life is 4 weeks.
2. After un-packing, It is necessary to bake the parts for 6 hours in  $125 \pm 5$  degree environment before soldering.