

SAC1315

Absorptive SPST Switch Module 6~12GHz

Rev1.0

Features

- Frequency: 6~12 GHz
- Insertion Loss: 1.5 dB
- Isolation: 75 dB
- SW Speed: 150 ns
- DC Power Supply @+5V/-5V: 80mA

Typical Applications

- Radar and ECM
- RF/ Microwave radio
- Military and Space
- Test and Measurement

General Description

SAC1315 is an absorptive SPST switch module manufactured using microwave hybrid integration technology. The operating frequency is from 6 to 12 GHz with 1.5 dB of insertion and 75 dB of isolation.

Electrical Performance

Parameter	Min.	Typ.	Max.	Units
Frequency Range	6	—	12	GHz
Insertion Loss	—	1.5	1.8	dB
Isolation	75	—	—	dB
VSWR	—	—	1.5	:1
P-0.1db	—	30	—	dBm
SW Speed	—	—	150	ns
DC Power Supply @+5V/-5V	—	—	80	mA
Operation Temp	-20	—	+60	°C
Storage Temp	-40	—	+85	°C

Mechanical Outline

All dimensions are in millimeters

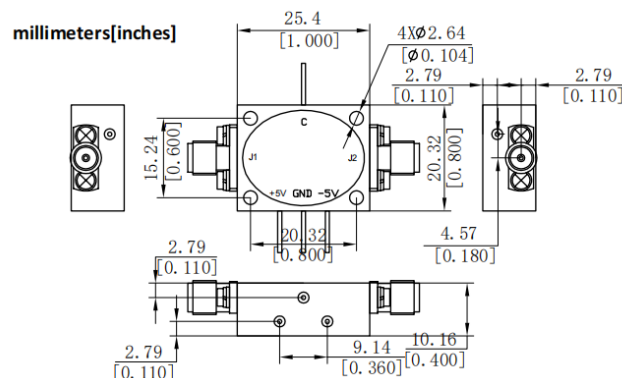

C	
0	ON
1	OFF
1:3.3-5V	
0:0-0.5V	

SuperApex, LLC

1580 S. Milwaukee Ave., Suite 405, Libertyville, IL 60048, USA
 Tel: 1-847-505-8319, 1-847-573-9866
 E-mail: sales@superapexco.com
 Website: www.superapexco.com