

SAC5003CR7



GaN MMIC Power Amplifier
8GHz~12GHz 45.5dBm

Rev 1.0

Features

- Frequency: 8GHz~12GHz
- Small Signal Gain: 29dB
- Output Power: 45.5dBm
- PAE: 30%
- Package: Metal-Ceramic-Package (CR7)
- Supply Voltage: +28V/-Vg

Typical Applications

- Point-to-Point Radios
- Weather Radar

General Description

SAC5003CR7 is a X-band power amplifier delivering 45.5dBm with 30% power added efficiency from 8GHz to 12GHz. No external matching is required to achieve full X-band operation.

Electrical Performance

$T_{BASE}=23^{\circ}C$, $V_D=+28V$, $I_{DQ}=2.3A$, $Z_0=50\Omega$, $T=1mS$, Duty Cycle=10%

Parameter	Min.	Typ.	Max.	Units
Frequency Range	8	—	12	GHz
Small Signal Gain	—	29	—	dB
Power Gain	—	17	—	dB
Reverse Isolation	—	50	—	dB
RF Input Port Return Loss	—	-12	—	dB
Output Power	—	45.5	—	dBm
Drain Voltage (V_D)	—	28	—	V
Gate Current	—	2	16	mA
Supply Current (I_D)*	—	—	6	A

*Adjust Vg between -2.5V to -1.5V to achieve $I_{DQ}=2.3A$, and typical Vg voltage is -2V

Absolute Maximum Ratings

Maximum Input Power	+30dBm	Operating Temperature (T_{BASE})	-55°C~+85°C
Channel Temperature	230°C	Storage Temperature	-55°C~+180°C
Maximum V_D	+32V	V_G Range	-5V~-1 V
Mounting Temperature	320°C,30s		

SuperApex, LLC

1580 S. Milwaukee Ave. Suite 405, Libertyville, IL 60048, USA
Tel: 1-847-505-8319, 1-847-573-9866
E-mail: sales@superapexco.com
Website: www.superapexco.com

SAC5003CR7



GaN MMIC Power Amplifier
8GHz~12GHz 45.5dBm

Rev 1.0

Typical Performance Curve

The following curves are taken from SAC5003CR7 evaluation board. De-embedding operation has been implemented. $V_D=+28V$, $I_{DQ}=2.3A$, $T_{BASE}=+25^{\circ}C$

Small Signal Gain(dB) vs.Frequency

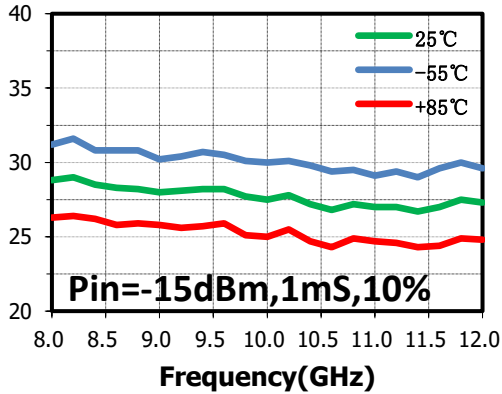

Output Power(dBm) vs.Frequency

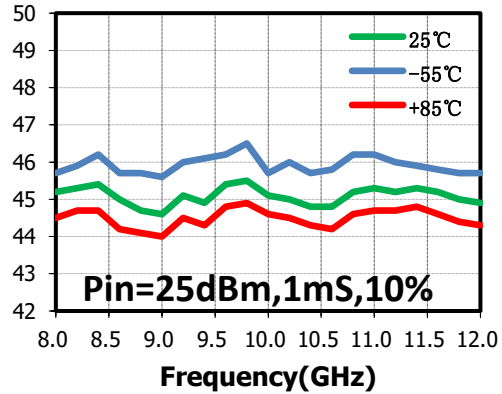

Output Power(dBm) vs.Frequency

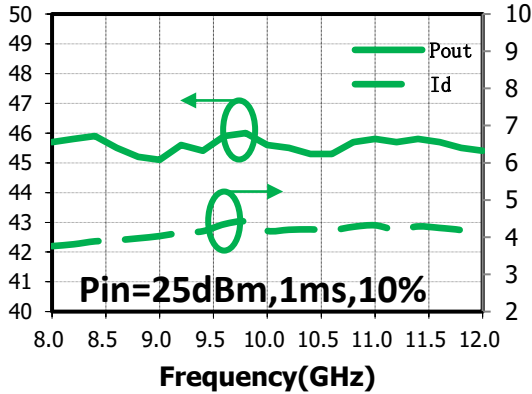

PAE(%) vs.Frequency

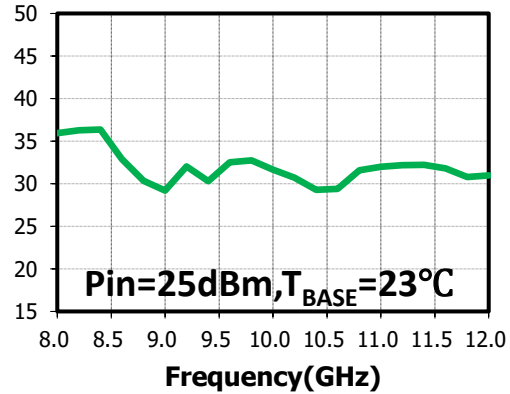

2nd Harmonic (dBc) vs. Frequency

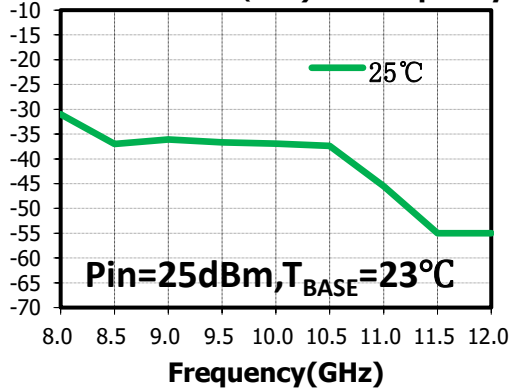

3rd Harmonic(dBc) vs. Frequency

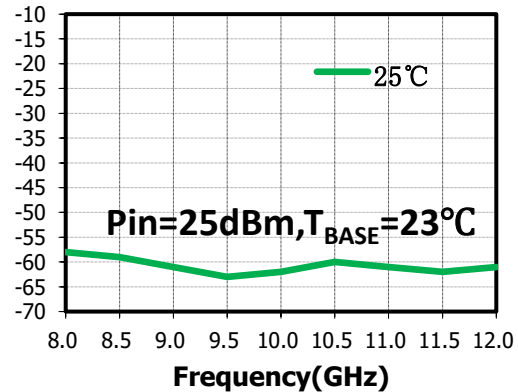

SuperApex, LLC

1580 S. Milwaukee Ave. Suite 405, Libertyville, IL 60048, USA
Tel: 1-847-505-8319, 1-847-573-9866
E-mail: sales@superapexco.com
Website: www.superapexco.com

SAC5003CR7



GaN MMIC Power Amplifier
8GHz~12GHz 45.5dBm

Rev 1.0

Output Power(dBm) vs.Pin,f=8GHz

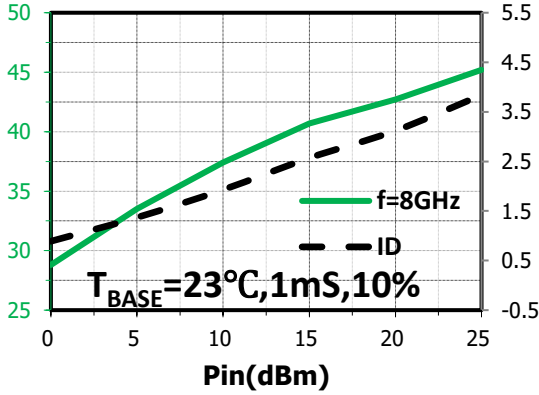

Output Power(dBm) vs.Pin,f=9GHz

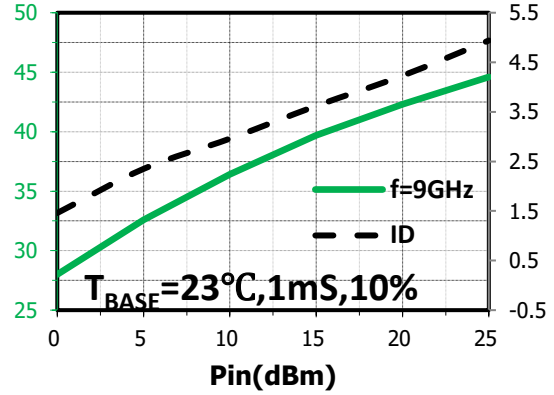

Output Power(dBm) vs.Pin,f=10GHz

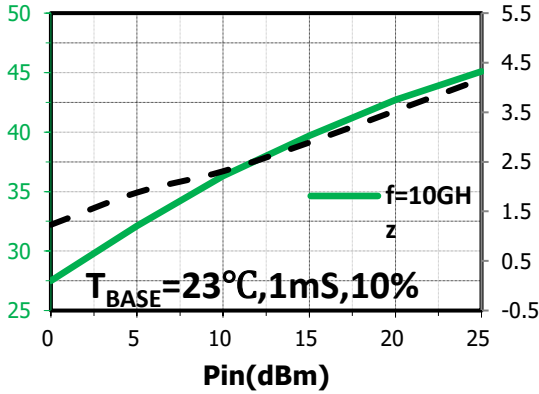

Output Power(dBm) vs.Pin,f=11GHz

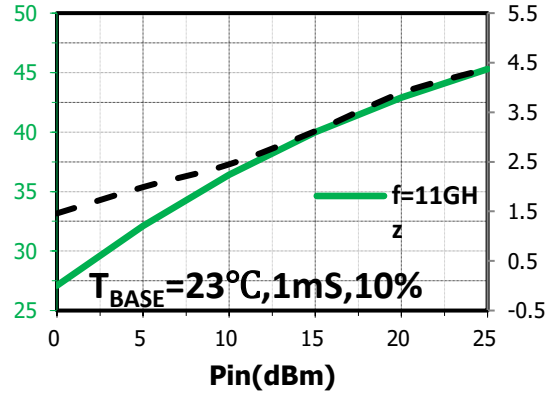

Output Power(dBm) vs.Pin,f=12GHz

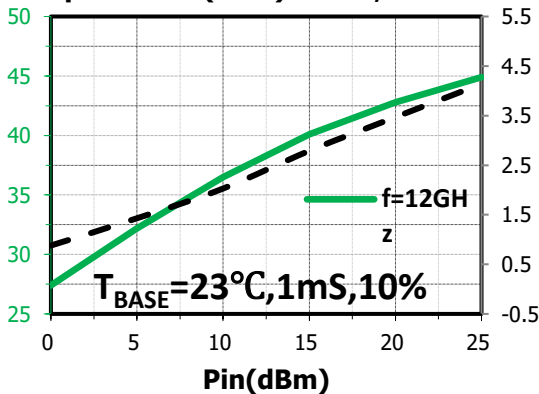

Thermal Resistance

Parameter	Conditions	Value	Unit
θ_{JC1}	$V_D=+28V, T_{BASE}=+70^\circ C, Pin=+25dBm, CW, f=10GHz$	1.52	$^\circ C/W$

SuperApex, LLC

1580 S. Milwaukee Ave. Suite 405, Libertyville, IL 60048, USA
 Tel: 1-847-505-8319, 1-847-573-9866
 E-mail: sales@superapexco.com
 Website: www.superapexco.com

SAC5003CR7



GaN MMIC Power Amplifier
8GHz~12GHz 45.5dBm

Rev 1.0

Outline Drawing

(All dimensions in mm)

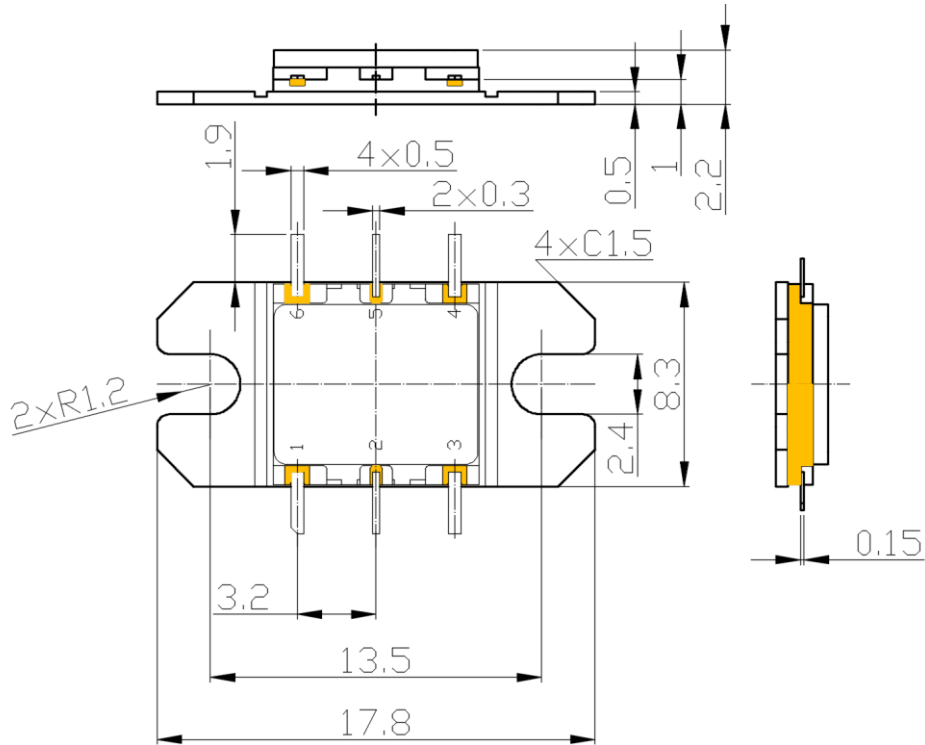

Pin Descriptions

Pin No.	Function	Pin No.	Function
1	Gate	4	Drain
2	RF input, AC Coupled	5	RF Output, AC Coupled
3	Gate	6	Drain

Application Circuit

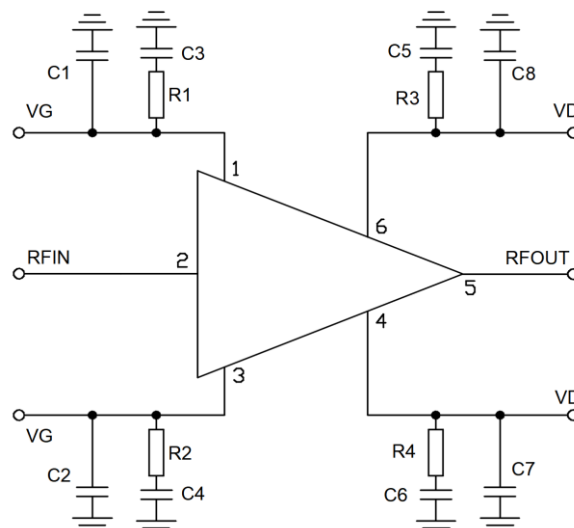

SuperApex, LLC

1580 S. Milwaukee Ave. Suite 405, Libertyville, IL 60048, USA
Tel: 1-847-505-8319, 1-847-573-9866
E-mail: sales@superapexco.com
Website: www.superapexco.com

SAC5003CR7



GaN MMIC Power Amplifier
8GHz~12GHz 45.5dBm

Rev 1.0

BOM

Reference Des.	Value	Part Number	Manuf.	Size
C1, C2	0.47 μ F	—	—	0805
C3~C6	0.022 μ F	—	—	0603
C7, C8	0.22 μ F	—	—	0603
R1~R8	2.2 Ω	—	—	0603

Notes

- SAC5003CR7 requires VDx and VGx bias.
Turn-on: Apply VGx, Apply VDx, Apply RFIN signal.
Turn-off: Remove RFIN signal, Decrease VG to -5V(pinch-off), Decrease VD to 0 V;
- The flange of package may be attached using screws, recommended torque for screw mounting is 10N-cm;
- The surface finish of the heat sink should be better than 0.8 μ m, and the surface flatness must be better than 10 μ m;
- Silicon based heat sink compounds should not be used for the thermal conductive grease. They cause poor grounding of the source flange. contamination and long-term degradation of thermal resistance between the FET package and heat sink;
- The chip is an Electrostatic Sensitive Device;
- The maximum soldering temperature for device pins is 400 °C/3s.

Revision History

Revision	Date	Comment
1.0	Jul. 3, 2024	First Release

SuperApex, LLC

1580 S. Milwaukee Ave. Suite 405, Libertyville, IL 60048, USA
Tel: 1-847-505-8319, 1-847-573-9866
E-mail: sales@superapexco.com
Website: www.superapexco.com