

SAC3145

GaAs MMIC Power Amplifier
2GHz~6GHz 30dBm

Rev 1.0

Features

- Frequency: 2GHz~6GHz
- Small Signal Gain: 21dB
- Output P_{1dB}: 30dBm CW
- PAE: 29%@OP-1dB,f=4GHz
- IM3: -30dBc, 23dBm/Tone@4GHz
- Die Size: 2.3mm × 1.39mm × 0.1mm
- Supply Voltage: +8V/-Vg
- Packaged: Bare Die

General Description

SAC3145 is a S-band and C-band GaAs power amplifier. SAC3145 provides 21 dB of gain, and 30dBm of output power for 1 dB compression (Typ.) from a +8 supply.

The surface of SAC3145 chip is covered with dielectric layer protective layer, which has good environmental adaptability and stability. At the same time, the chip adopts on-chip metallization process to ensure good grounding. The back of the chip is metallized.

Typical Applications

- S-band and C-band multifunction radar
- Point-to-Point Radios

Functional Diagram

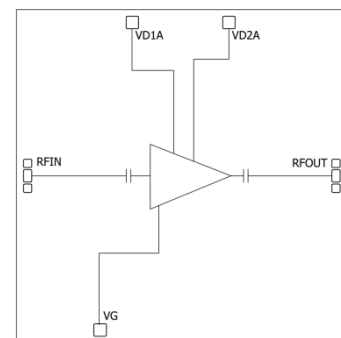

Electrical Performance

T_A=25°C, V_D=+8V, I_{DQ}=0.45A, Z₀=50Ω, CW

Parameter	Min.	Typ.	Max.	Units
Frequency	2	—	6	GHz
Small Signal Gain	20	21	—	dB
Small Signal Gain Flatness	—	±1	—	dB
Reverse Isolation	—	-50	—	dB
RF input port VSWR	—	1.7	2.8	:1
RF output port VSWR	—	1.6	2.2	:1
Power-Added Efficiency	—	29	—	%
Output P _{1dB}	28	30	—	dBm
IM ₃ *	—	30	—	dBc
Drain Voltage (V _D)	7	—	8.5	V
Gate Current	—	20	—	μA
Supply Current(I _D)* *	—	—	0.7	A
Thermal Resistance	—	28.8	—	°C/W

* P_{out}/Tone=23dBm, f_c=4GHz, Δf=4MHz

**Adjust the V_g voltage (-1 ~ -0.6v) so that the I_{DQ} is about 0.45A, and the typical V_g voltage is -0.65V

SuperApex, LLC

1580 S. Milwaukee Ave Suite 405, Libertyville, IL 60048, USA
Tel: 1-847-505-8319, 1-847-573-9866
E-mail: sales@superapexco.com
Website: www.superapexco.com

SAC3145



GaAs MMIC Power Amplifier
2GHz~6GHz 30dBm

Rev 1.0

Absolute Maximum Ratings

Maximum Input Power	+24dBm(30s)	Operating Temperature (Backside)	-55°C~+85°C
Channel Temperature	165°C	Storage Temperature	-55°C~+150°C
Maximum V _D Supply	+8.5V	V _G Range	-1.3V(Pinch Off)~-0.5V

Typical Performance Curve

The following data are obtained by SAC3145 evaluation board test, V_D = + 8V, I_{DQ} = 0.45A, working mode CW, T_A = + 25°C

Small Signal Gain(dB) vs.Temperature

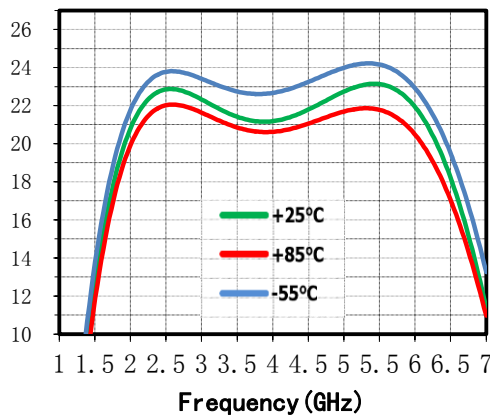

Isolation(dB) vs.Temperature

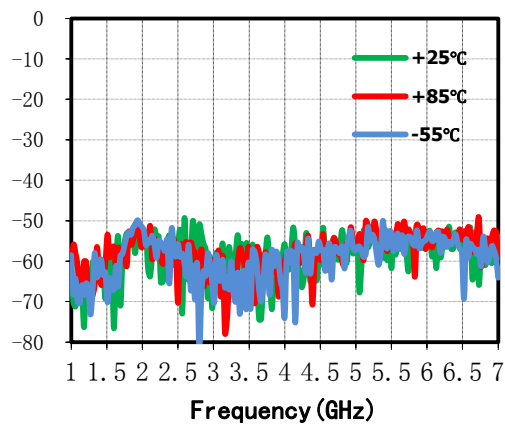

Input VSWR(:1) vs.Temperature

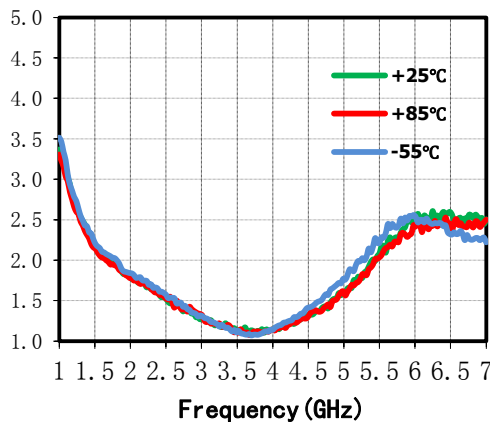

Output VSWR(:1) vs.Temperature

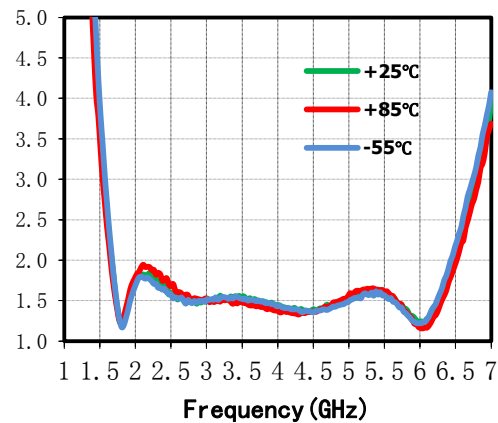

SuperApex, LLC

1580 S. Milwaukee Ave Suite 405, Libertyville, IL 60048, USA
Tel: 1-847-505-8319, 1-847-573-9866
E-mail: sales@superapexco.com
Website: www.superapexco.com

SAC3145



GaAs MMIC Power Amplifier
2GHz~6GHz 30dBm

Rev 1.0

OP-1dB (dBm) vs. Temperature

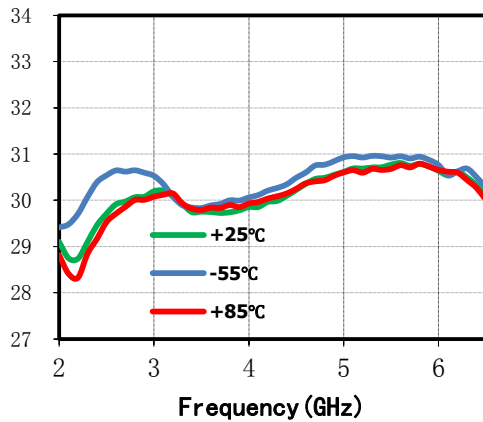

OP-3dB (dBm) vs. Temperature

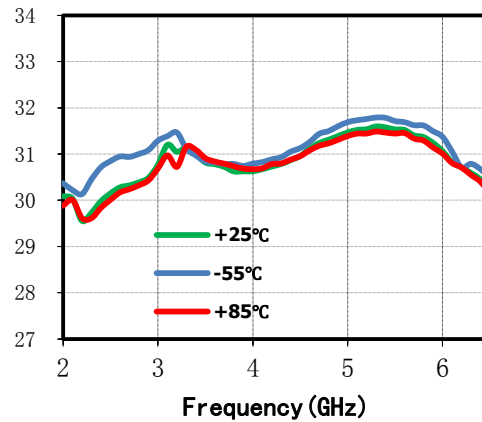

OP-1dB (dBm) vs. Bias

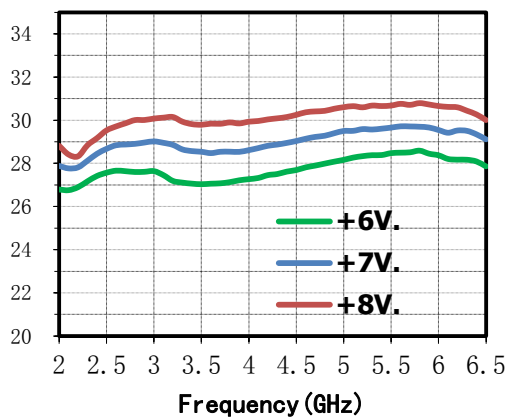

PAE (%) vs. Comp. point

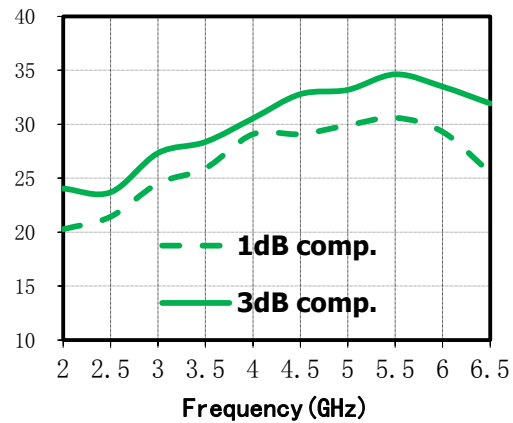

IM3 (dBc) vs. Pout/Tone

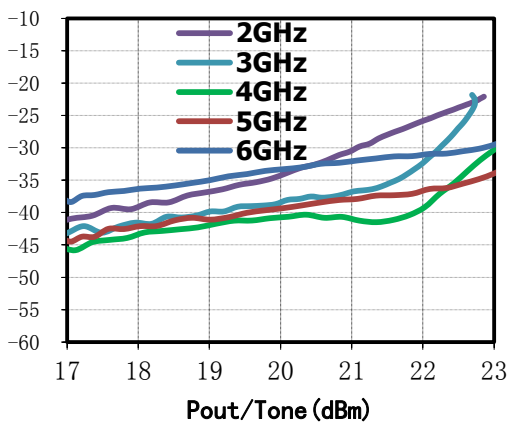

SuperApex, LLC

1580 S. Milwaukee Ave Suite 405, Libertyville, IL 60048, USA
Tel: 1-847-505-8319, 1-847-573-9866
E-mail: sales@superapexco.com
Website: www.superapexco.com

SAC3145

GaAs MMIC Power Amplifier
2GHz~6GHz 30dBm

Rev 1.0

Outline Drawing (All dimensions in μm)

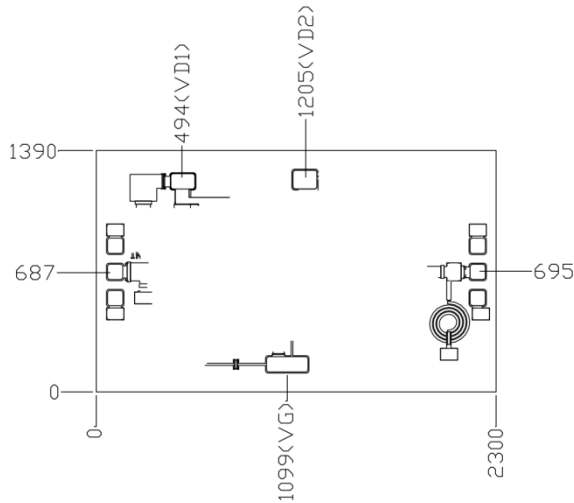

Assembly Diagram

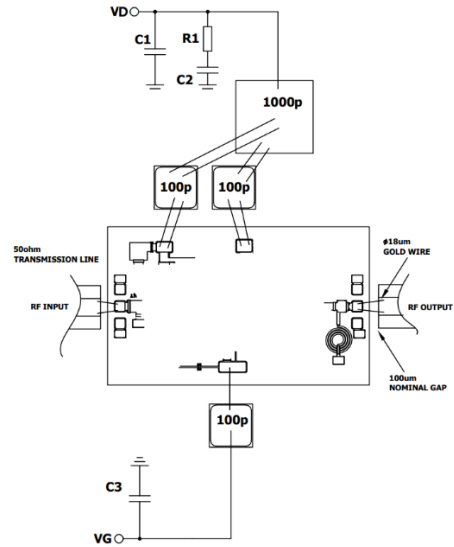

Components List

Reference Des.	Value	Part Number	Manuf.	Size
C1, C3	10 μF	—	—	0805
C2	0.47 μF	—	—	0603
R1	2.2 Ω	—	—	0603

SAC3145 Chip Test Fixture

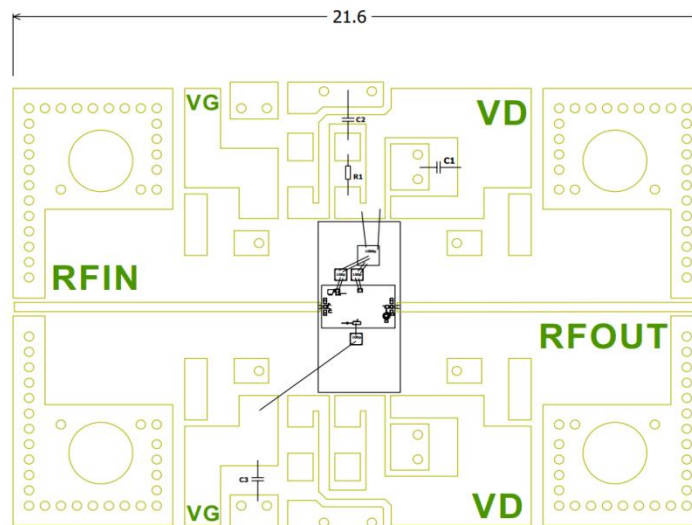

SuperApex, LLC

1580 S. Milwaukee Ave Suite 405, Libertyville, IL 60048, USA
Tel: 1-847-505-8319, 1-847-573-9866
E-mail: sales@superapexco.com
Website: www.superapexco.com

SAC3145



GaAs MMIC Power Amplifier
2GHz~6GHz 30dBm

Rev 1.0

Attention:

1. SAC3145 requires drain positive voltage (V_{Dx}) and grid negative voltage (V_{Gx}) bias. Before applying drain positive voltage, ensure that grid negative voltage has been applied. When closing, ensure that drain positive voltage is turned off before grid negative pressure;
2. The length of RF input / output gold wire shall be shortened as much as possible. It is recommended to use gold wire with a diameter of 25 μ m;
3. It is recommended to use vacuum AuSn eutectic welding.

Revision History

Revision	Date	Comment
1.0	August 26, 2021	First Release

SuperApex, LLC

1580 S. Milwaukee Ave Suite 405, Libertyville, IL 60048, USA
Tel: 1-847-505-8319, 1-847-573-9866
E-mail: sales@superapexco.com
Website: www.superapexco.com