

SAC3153Q8



GaAs MMIC Power Amplifier
8GHz~12GHz 38dBm

Rev 1.0

Features

- Frequency: 8GHz~12GHz
- Small Signal Gain: 23dB
- Output P_{3dB}: 38dBm
- Package size: QFN8x8
- Supply Voltage: +7V/-V_g

Typical Applications

- Point-to-Point Radios

General Description

SAC3153Q8 is a X-band GaAs MMIC power amplifier. SAC3153Q8 provides 23dB of gain, and 38dBm of output power for 3dB compression from +7V supply.

Electrical Performance

T_A=25°C, V_D=+7V, I_{DQ}=2A, Z₀=50Ω, CW

Parameter	Min.	Typ.	Max.	Units
Frequency Range	8	—	12	GHz
Small Signal Gain	19	23	—	dB
Small Signal Gain Flatness	—	±2	—	dB
Reverse Isolation	—	-70	—	dB
RF Input Port Return Loss	—	-8	—	dB
Output P _{1dB}	37.5	38	—	dBm
Drain Voltage (V _D)	7	—	8	V
Gate Current	—	—	23	mA
Supply Current (I _D)***	—	—	5.5	A
Thermal Resistance**	—	2.8	—	°C/W

** Measurement taken at P_{out} = OP_{3dB}, IR method. 100% DC power is dissipated on the device the thermal resistance is 3.1°C/W

*** Adjust V_g between -1.5V to -0.4V to achieve I_{DQ}= 2A, and typical V_g voltage is -0.9V.

Absolute Maximum Ratings

Maximum Input Power	+27dBm	Operating Temperature (Backside)	-55°C~+85°C
Channel Temperature	150°C	Storage Temperature	-55°C~+150°C
Maximum V _D	+8.5V	V _G Range	-3V~-0.4V

SuperApex, LLC

1580 S. Milwaukee Ave. Suite 405, Libertyville, IL 60048, USA
Tel: 1-847-505-8319, 1-847-573-9866
E-mail: sales@superapexco.com
Website: www.superapexco.com

SAC3153Q8



GaAs MMIC Power Amplifier
8GHz~12GHz 38dBm

Rev 1.0

Typical Performance Curve

$V_D = +8V, I_{DQ} = 2A, CW, T_A = +25^\circ C$

Small Signal Gain(dB) vs. Temperature

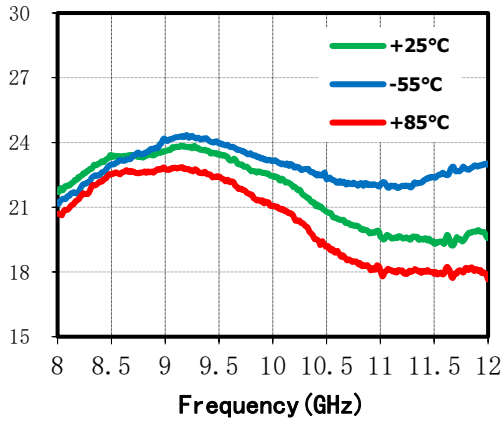

RF Input RL (dB) vs. Temperature

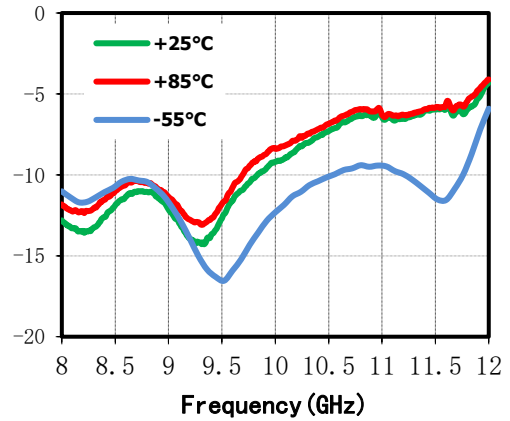

OP-3dB (dBm), PAE (%) vs. Frequency

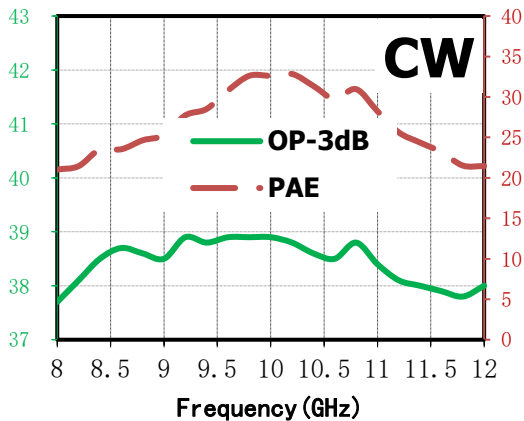

Psat (dBm), PAE (%) vs. Frequency

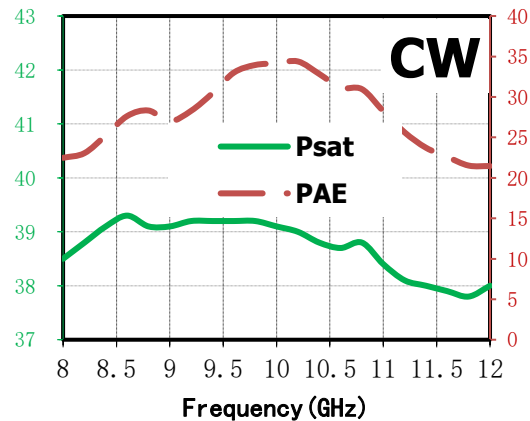

2nd Harmonic Rej. vs. Frequency

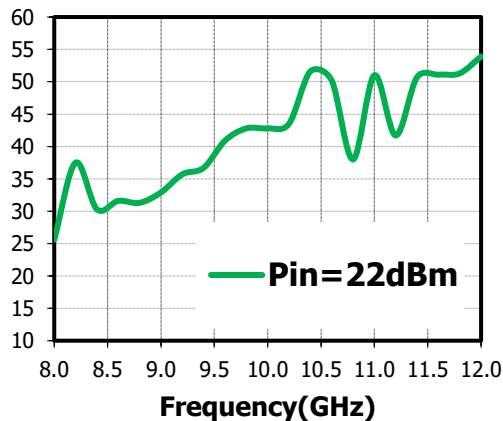

Pout (dBm), PAE (%), ID(A) vs. Pin, f=8GHz

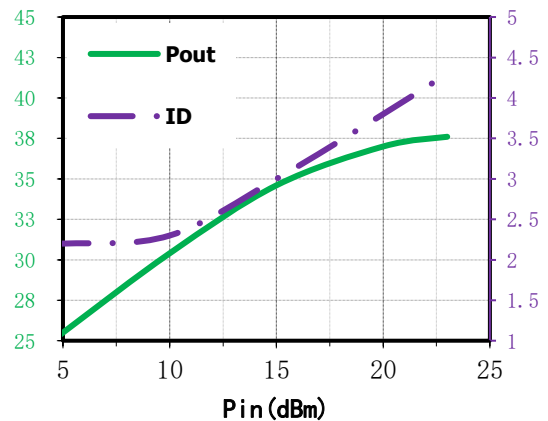

SuperApex, LLC

1580 S. Milwaukee Ave. Suite 405, Libertyville, IL 60048, USA
Tel: 1-847-505-8319, 1-847-573-9866
E-mail: sales@superapexco.com
Website: www.superapexco.com

SAC3153Q8



GaAs MMIC Power Amplifier
8GHz~12GHz 38dBm

Rev 1.0

Pout (dBm)、PAE (%)、ID(A) vs. Pin,f=8.5GHz

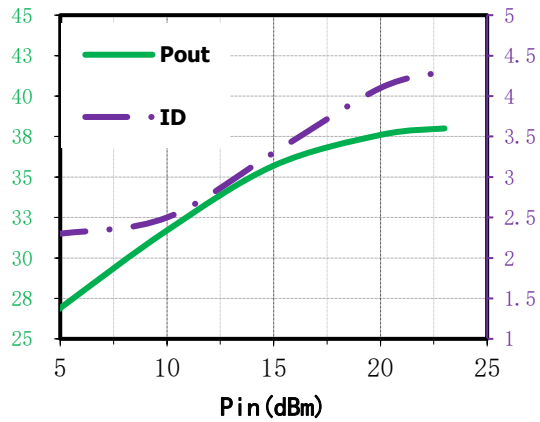

Pout (dBm)、PAE (%)、ID(A) vs. Pin,f=9GHz

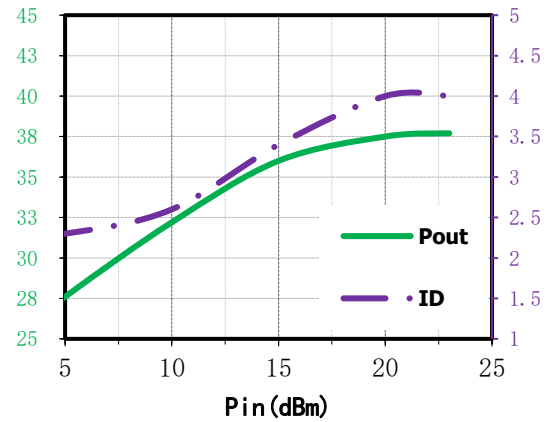

Pout (dBm)、PAE (%)、ID(A) vs. Pin,f=9.5GHz

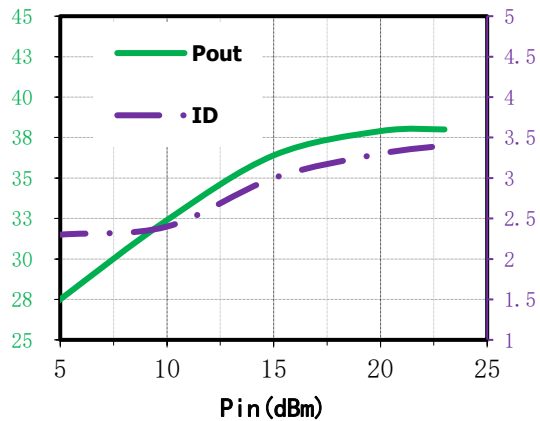

Pout (dBm)、PAE (%)、ID(A) vs. Pin,f=10GHz

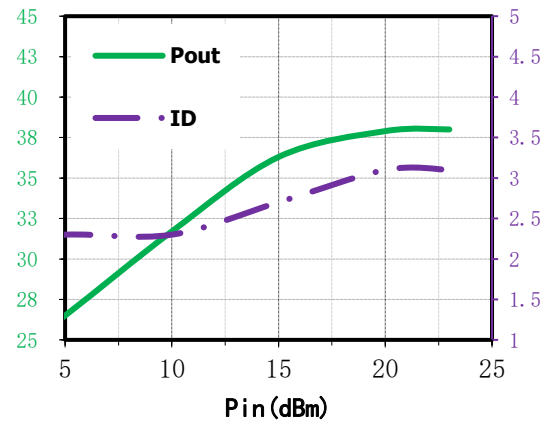

Pout (dBm)、PAE (%)、ID(A) vs. Pin,f=10.5GHz

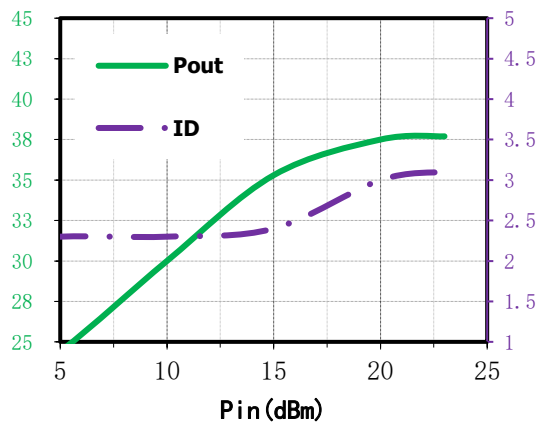

Pout (dBm)、PAE (%)、ID(A) vs. Pin,f=11GHz

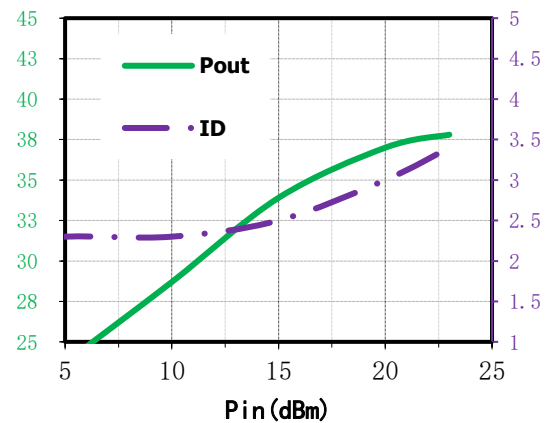

SuperApex, LLC

1580 S. Milwaukee Ave. Suite 405, Libertyville, IL 60048, USA
Tel: 1-847-505-8319, 1-847-573-9866
E-mail: sales@superapexco.com
Website: www.superapexco.com

SAC3153Q8



GaAs MMIC Power Amplifier
8GHz~12GHz 38dBm

Rev 1.0

Pout (dBm)、PAE (%)、ID(A) vs. Pin,f=11.5GHz

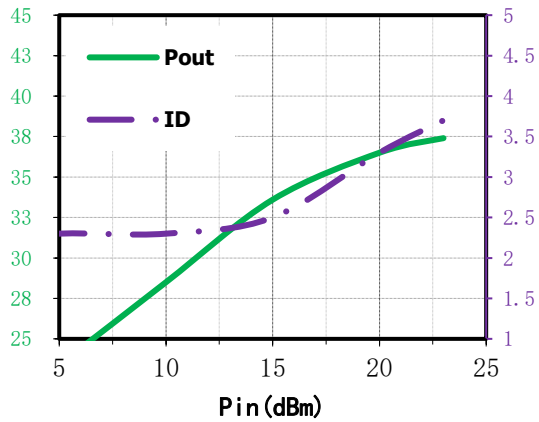

Pout (dBm)、PAE (%)、ID(A) vs. Pin,f=12GHz

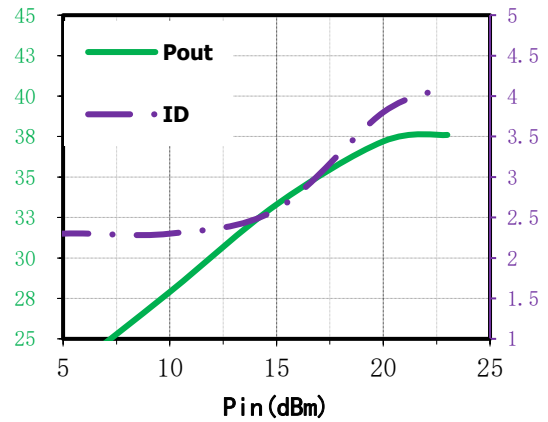

Outline Dimension (mm)

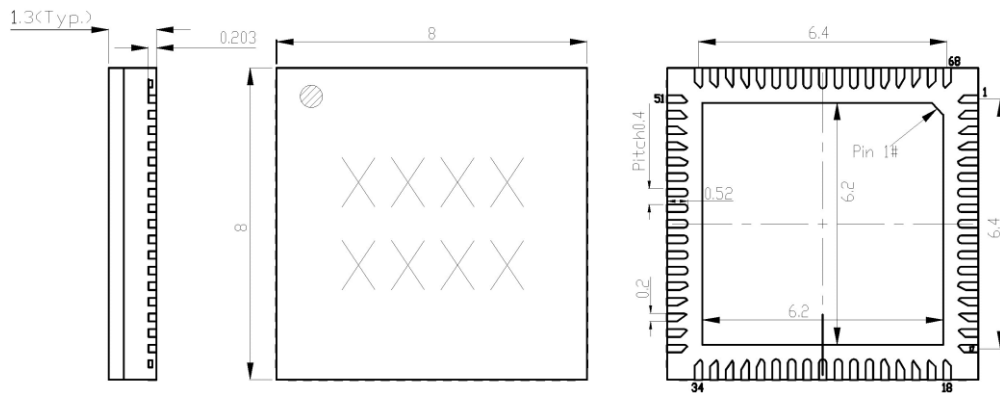

SuperApex, LLC

1580 S. Milwaukee Ave. Suite 405, Libertyville, IL 60048, USA
 Tel: 1-847-505-8319, 1-847-573-9866
 E-mail: sales@superapexco.com
 Website: www.superapexco.com

SAC3153Q8



GaAs MMIC Power Amplifier
8GHz~12GHz 38dBm

Rev 1.0

Application Circuit

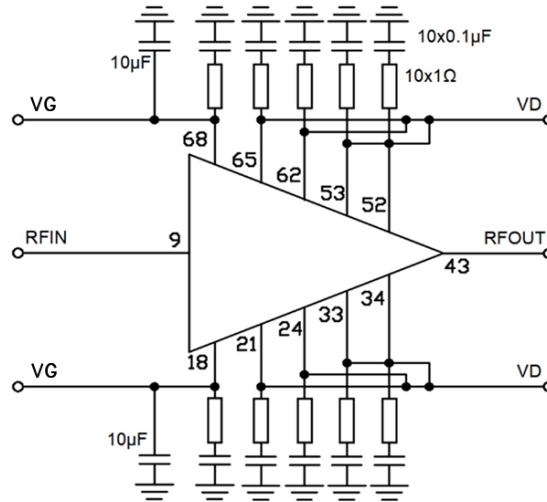

Pin Descriptions

Pin No.	Function	Pin No.	Function	Pin No.	Function	Pin No.	Function	Pin No.	Function
1	GND	15	GND	29	GND	43	RFOUT	57	GND
2	GND	16	GND	30	VDAUX	44	GND	58	VDAUX
3	GND	17	GND	31	VDAUX	45	GND	59	VDAUX
4	GND	18	VG1	32	GND	46	GND	60	GND
5	GND	19	GND	33	VD3B	47	GND	61	GND
6	GND	20	GND	34	VD3B	48	GND	62	VD2A
7	GND	21	VD1B	35	GND	49	GND	63	GND
8	GND	22	GND	36	GND	50	GND	64	GND
9	RFIN	23	GND	37	GND	51	GND	65	VD1A
10	GND	24	VD2B	38	GND	52	VD3A	66	GND
11	GND	25	GND	39	GND	53	VD3A	67	GND
12	GND	26	GND	40	GND	54	GND	68	VG2
13	GND	27	VDAUX*	41	GND	55	VDAUX		
14	GND	28	VDAUX	42	GND	56	VDAUX		

*The VDAUX pins should be keep floating or connect to VD together

SuperApex, LLC

1580 S. Milwaukee Ave. Suite 405, Libertyville, IL 60048, USA
Tel: 1-847-505-8319, 1-847-573-9866
E-mail: sales@superapexco.com
Website: www.superapexco.com

SAC3153Q8

GaAs MMIC Power Amplifier
8GHz~12GHz 38dBm

Rev 1.0

Evaluation Board

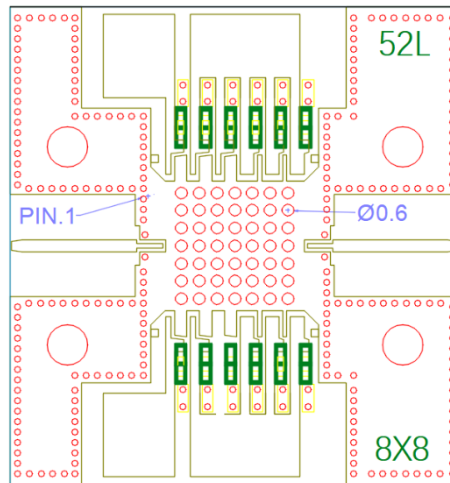

Superapex recommend the PCB fabricated using Rogers 4350b $t=0.254$ and using best practices for high frequency RF design. The RF input and RF output traces should have a $50\ \Omega$ characteristic impedance.

The bottom center pad of SAC3153Q8 is used for RF grounding and heat dissipation. For best heat dissipation, copper-filled vias are highly recommended, SAC3153Q8 is high power dissipation surface mount components and require a well-designed thermal mount. All the heat generated by the device is expected to be removed through the bottom heat slug with a low thermal resistance path to the chassis.

The use of multiple copper-filled vias or solder-filled vias under the package's heat slug while using an indium foil between the PCB and chassis provides a low thermal resistance mount, Insufficient number of vias or insufficient solder filling will significantly affect the heat dissipation process of the device, and then reduce the performance or even damage the device.

Notes:

1. SAC3153Q8 requires V_{Dx} and V_{Gx} bias.
Turn-on: Apply V_{Gx}, Apply V_{Dx}, Apply RFIN signal.
Turn-off: Remove RFIN signal, Decrease V_G to -1.5 V (pinch-off), Decrease V_D to 0 V
2. The moisture resistant grade of products is 2a, the storage environment $\leq 30^\circ\text{C}/60\%\text{RH}$, the surrounding workshop life is 4 weeks;
3. After un-packing, it is necessary to bake the parts for 6 hours in $125\pm 5^\circ$ environment before soldering;
4. GaAs MMIC devices are susceptible to damage from Electrostatic Discharge. Proper precautions should be observed during handling, assembly, and test;
5. Ultrasonic cleaning is prohibited.

Revision History

Revision	Date	Comment
1.0	Mar. 13, 2025	First Release

SuperApex, LLC

1580 S. Milwaukee Ave. Suite 405, Libertyville, IL 60048, USA
Tel: 1-847-505-8319, 1-847-573-9866
E-mail: sales@superapexco.com
Website: www.superapexco.com